

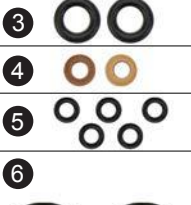

PCP Pump

Specifications

Length:	25.6 inches / 650mm retracted 44.1 inches / 1120mm expanded
Weight:	5.29 lbs / 2.4kg
Maximum Pressure:	4500 psi / 310 bar
Time:	At 200 bar 2 hours continuously
Output Nut:	M10x1
Quick Connector:	8/16" / 8mm size

Included Accessories

	
	
	
Item	Qty
1. Special Wrench	1
2. T Spanner	1
3. High Pressure Stem Sealing Ring	2
4. High Pressure Piston Ring	2
5. O-Ring	5
6. Other Tube Piston Ring	2
7. Check Valve	2
8. Check Valve Spring	2
9. Sealing Gasket of Bleed Valve	2
10. High Pressure Piston Spring	2
11. Low Pressure Piston Ring	2
12. High Pressure Spool Valve	2
13. Inlet Hole One Way Seal Ball	2
14. Allen Spanner	1
15. Maintenance Grease	1

WARNING

DO NOT disassemble any joint when there is residual gas, it is dangerous to take apart the joint in this situation.

DO NOT put your hand near the air vent or point it at people when you release the bleed valve screw, it can cause serious damage.

DO NOT add lubricating oil to the pump. Use appropriate grease as necessary.

Install

Open the package and inspect all items. Read the instructions before use. Familiarize yourself with proper operational method. The wrong operation can be harmful to the user and may damage the pump.

Loosen the belt on the pump, unscrew the bleed valve, pump up and down 10 times to empty the pump. Tighten the bleed valve and pump up to 200 bar (usually 6 times) then wait for 2 minutes under 200 bar state to check whether there is leakage (check pressure gauge needle). The best way to check for a leakage point is to place the pump underwater.

Operation

1. Remove test plug from pump by pressing down on silver ring.
 2. Before pumping, be sure the hose has no knots. Pull and push the pump quickly. You will feel resistance when the pressure in the container reaches 100 bar, this is normal.
 3. Connect the pump to the container according to the container's instructions.
- Note: Before starting to fill the container, read the instruction booklet about that container to ensure the correct amount of pressure.
4. Check that the bleed valve is tightened correctly. Keep the pump steady by standing on the base of the pump. Pull and push the pump quickly to inflate the gas.
 5. Open the bleed valve screw to relieve pressure in the hose. Make sure the pressure gauge needle is at 0 before disconnecting the container. Note: You could directly open the bleed valve if the container has a unidirectional valve. If your container does not have a unidirectional valve, first turn off the valve to release residual gas in the pump barrel and hose when filling the container. It is normal to find small amounts of gas and water leaking from the bleed valve.
 6. Disconnect the pump from the container according to the container's instructions.

High Piston

1. First to screw the nut off.
2. Use T spanner to take the pole out.

Common Problems and Solutions

Problem 1: The needle of pressure gauge does not move or moves very slowly when pumping. Generally speaking a 0.5L standard container should cause the needle to reach the 200 bar when pumped for 420-450 times.

Reason: The needle has not moved or is moving very slowly is because of a leak.

Solution: To confirm leak place pump underwater to find a leakage point.

Problem 2: In the process of pumping, it pulls heavy and pump automatically pumps down

Reason: The stage 3 piston has a malfunction
See reverse side for additional information

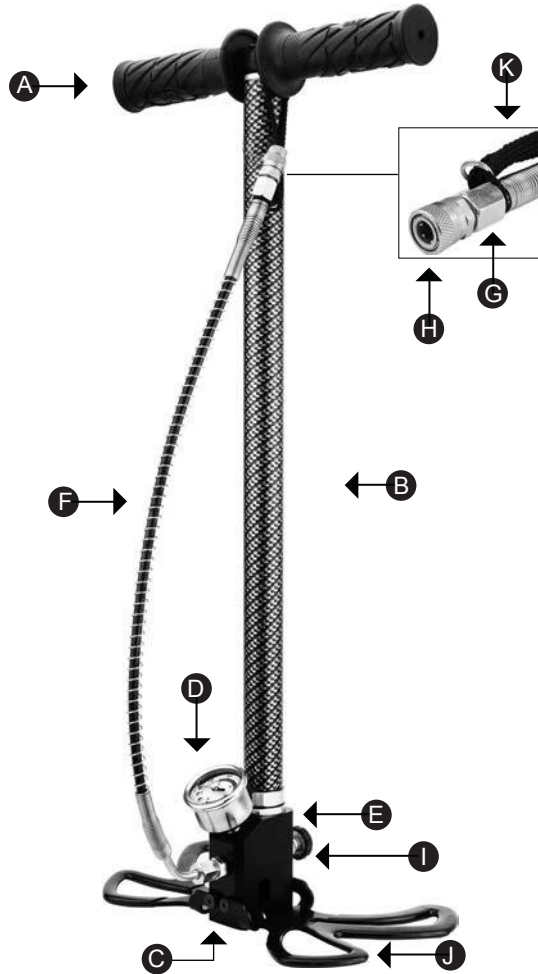

Parts of the Pump

- A - Rubber Grip
- B - Pump Barrel
- C - Base Plate
- D - Pressure Gauge
- E - Moisture Filter
- F - Hose
- G - Quick Connector
- H - Test Plug
- I - Bleed Valve
- J - Folding Base Plate
- K - Belt

Solution 1: Open the bleed valve to take apart the tube and the connecting screw which is on the top of the pump barrel. Fill the tube with water or silicon oil (not included), then reassemble the pump, remove test plug and continuously pump (10 times). When the pump automatically sucks back remove any debris from the valve and replace the o-ring. See image 1.

Solution 2: Take apart the Level 3 piston set to find the leakage or change the o-ring.

Image 1

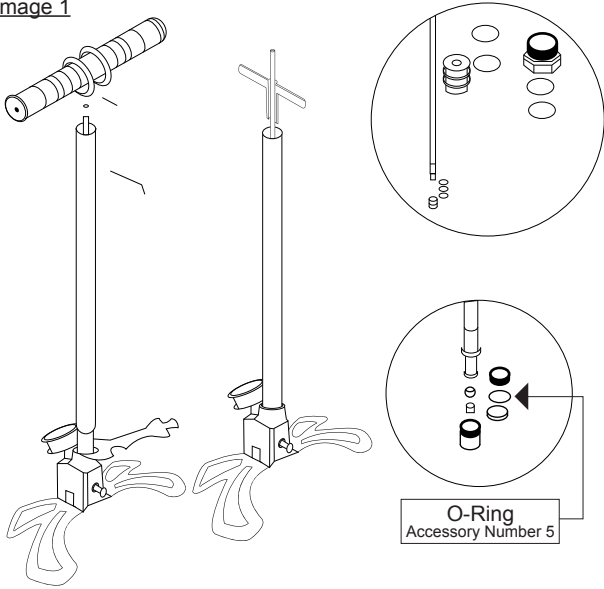

Problem 3: In the process of pumping the pull is very light but pushing down has resistance or it will automatically run up.

Reason: Setup instructions may have not been followed correctly.

Solution 1: Add lubricating oil or silicone oil, do not release excess gas in high pressure, this can cause a gas explosion if the pressure is above 150 bar resulting in a damaged check valve or a carbon deposit in the check valve.

Solution 2: Clean or replace the check valves when the pump automatically runs up. Use the included special wrench to open the base to replace or clean the check valve. See image 2.

Image 2

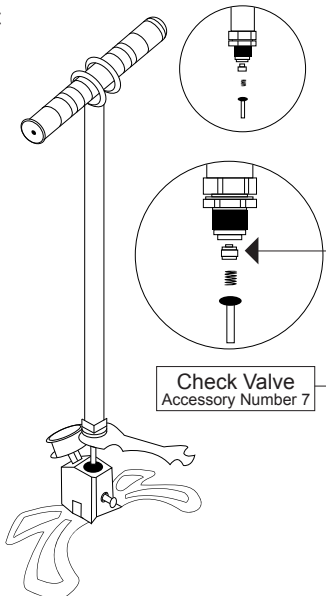

Problem 4: The resistance builds up when pulling and pushing the pump.

Reason: Dust may have accumulated on the seals surface and is interfering with the self-lubricating function. The pump now requires maintenance.

Solution: Disassemble pump, apply maintenance grease on a cloth, then dry wipe all sealing rings, cylinder surfaces, 5mm solid core rod and the whole external high-pressure piston. After assembly, ensure that all sliding surfaces have a thin layer of maintenance grease.

To test if there is enough lubrication pour out the excess maintenance grease and the base absorption ball inside. Empty the pump by pumping it about 50 times to discharge excess maintenance grease. Clean the base adsorption ball and check valve with detergent and water. Make sure items are dry and place them back into the base. Use the test plug to test the pump according to problem 3. When you feel a heavy pull during the inflation process, apply a small amount of maintenance grease. See image 3.

Image 3

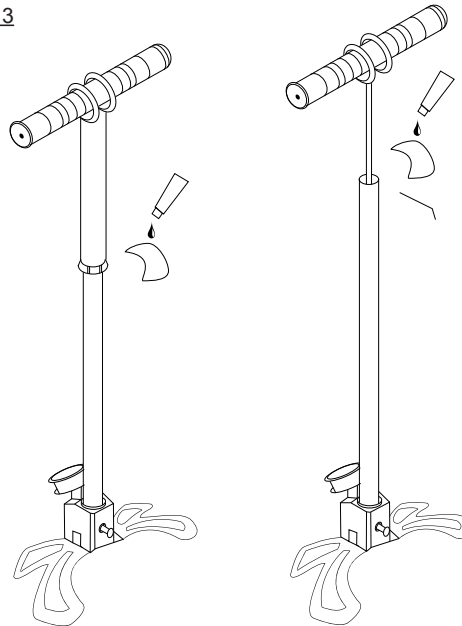

Problem 5: The pressure gauge needle is not at zero.

Reason: Lubricating oil and silicone oil was not added or drained properly causing an explosion under the pressure of 150 bar or higher. Damage may also been caused during transportation.

Solution: Pressure gauge needs to be replaced.

Note

You will hear a hissing and water sound when you release residual gas in the pump and hose. Normally a small volume of gas is released, if the volume of the gas is large the check valve may not work properly or the check valve is not fastened well. If the problem still exists contact the manufacturer.



1 YEAR LIMITED WARRANTY

PCP PUMP

WINBEST® by BARSKA®, as manufacturer, warrants this new product to be free of original defects in materials and/or workmanship for the length of time specified by this warranty. This warranty does not include damage caused by abuse, improper handling, installation, maintenance, normal wear-and-tear, unauthorized repairs or modifications and tampering in anyway.

This warranty is limited to the original purchaser and is not transferable. This warranty applies only to products purchased in the United States of America.

In the event of a defect within 30 days, the consumer must return the defective unit to the WINBEST® by BARSKA® dealer (the place of purchase) at his/her own expense.

Beyond 30 days, WINBEST® by BARSKA® products should be sent to the following address for warranty repairs. Products must be packed carefully and sturdily to prevent damage in transit, and returned freight prepaid to:

WINBEST® by BARSKA®
855 Towne Center Drive
Pomona, CA 91767

For additional and updated information
please visit www.barska.com

Please email info@barska.com or call 1.888.666.6769 for Return Merchandise Number (RMA#) before any returns.
NOTE: All merchandise received without a valid RMA# will be returned to shipper at his/her own expense.

- Please include all of the following when returning WINBEST® by BARSKA® products for service and/or replacement:
1. Please write your complete details (Name, Address, Telephone #, E-mail address, RMA#, etc.)
 2. Purchase receipt or Proof of Purchase. (Original/Copy)
 3. A brief explanation of the defect
 4. A Check/Money Order of \$30.00 to cover inspection, shipping and handling
- *Please allow 6-8 weeks for delivery

This product will either be replaced or repaired at the discretion of the warrantor. If it's a discontinued item, we will replace the product with an equivalent product. Should the repair not be covered by this warranty, an estimate will be sent for your approval. Non-warranty repairs or refurbishing are always provided at a reasonable cost.

WINBEST® by BARSKA® shall not be liable for any consequential, incidental and/or contingent damages whatsoever. We will not pay shipping, insurance or transportation charges from you to us, or any import fees, duties and or taxes. This warranty supersedes all previous Winbest® by BARSKA warranties.