

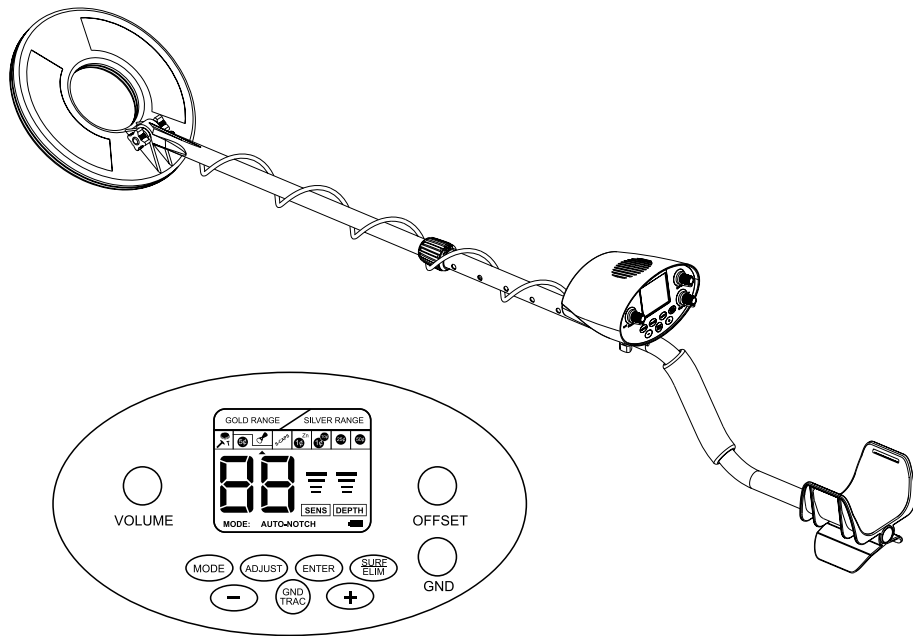

# Master-200 Edition Metal Detector

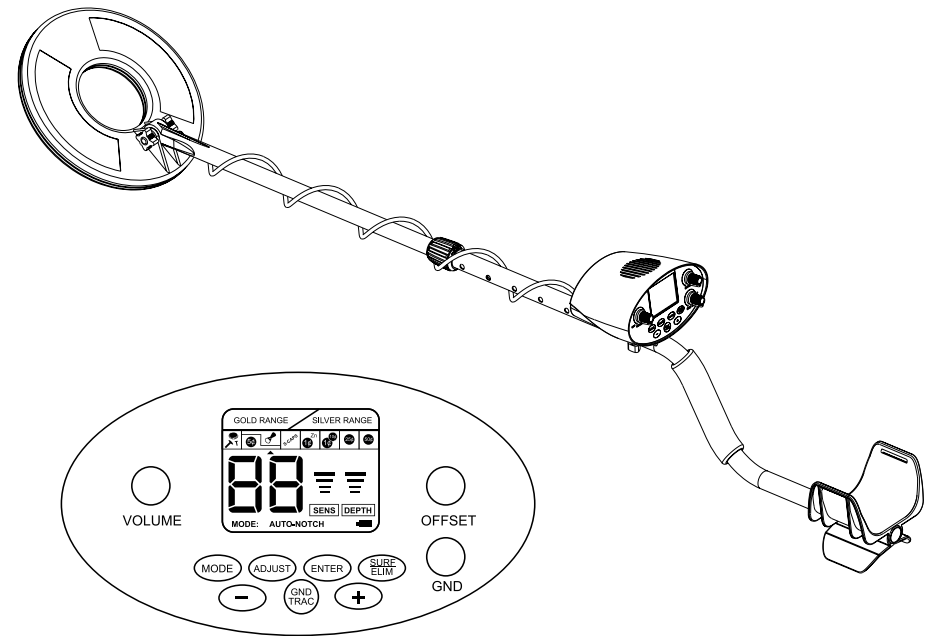

# Master-200 Edition Metal Detector



CONTENTS

Terminology		4
Preparation		5
	Parts of the Metal Detector	5
	Assembly	5
	Batteries	6
	Control Panel	7
	LCD Screen	7
	Basic Controls	8
Basic Operation		8
	Motion and Non-Motion Modes	8
	Power On	8
	Four Operation Modes	9
	Sensitivity Adjustment	10
	Offset / Frequency Tuning	11
	Surface Elimination	11
	Headphone Jack	11
	ATI, Audio Target Identification	11
Using the Detector		12
	Reading the Display	12
	Depth Indicator	13
	Indoor Testing	14
	Outdoor Testing	14
	Ground Balancing	16
	Pinpointing, Non-Motion Mode	17
Trouble Shooting		18
Care and Maintenance		18
Warranty		19

Notes Before Use

- This metal detector is a professional metal detector. As a sophisticated electronic device, the most difficult aspects in metal detecting have been preset.
- If you are new to using metal detectors, it is recommended to set the sensitivity to a low level in the event of false signals.
- Always begin at a low sensitivity level when using. After you have become familiar with the detector, you may try it at full sensitivity.
- This detector is for outdoor use only. Do not use indoors. Many home appliances can emit electromagnetic waves, and will interfere with the detector.
- For indoor testing, turn the sensitivity low and keep the search coil away from electronics such as microwave ovens, computers and TVs. If your detector beeps erratically, turn off the electronic appliances and lights, especially those with dimmer switches.
- Read this manual before using.

Treasure Hunter's Code of Ethics

A few basic rules you should follow while using your detector.

- Always get permission before searching any site.
- Respect the rights and property of others.
- Observe all national, state and local laws when treasure hunting.
- Never destroy historical or archaeological treasures. If you are not sure about an object you have found, contact a museum or historical society in your area.
- Leave the land and vegetation as is, and fill in any holes you dig.
- Use the detector only in safe areas.
- Dispose of any junk you may find, only in approved areas. Do not leave it for the next treasure hunter find.

**Terminology**

The following terms are used throughout the manual.

Elimination

Reference to a metal being “eliminated” means that the detector will not emit a tone, nor light up an indicator, when a specified object passes through the coil’s detection field.

Discrimination

When the detector emits different tones for different types of metals, and when the detector “eliminates” certain metals, we refer to this as the detector “discriminating” among different types of metals. Discrimination is an important feature of professional metal detectors. Discrimination allows the user to ignore trash and otherwise undesirable objects.

Notch

Notching is the elimination of an item, or range of items, within the metallic spectrum. We “notch-out” an object, or objects, selectively.

Auto Notch

It eliminates trash metals automatically and keep the detection for most coins. AUTO NOTCH range is preset and not adjustable.

Relic

A relic is an object of interest by reason of its age or its association with the past. Many relics are made of iron, but can also be made of bronze or precious metals.

Iron

Iron is a common, low-grade metal that is an undesirable target in certain metal detecting applications. Examples of undesirable iron objects are old cans, pipes, bolts, and nails. Sometimes, the desired target is made of iron. Property markers, for instance, contain iron. Valuable relics can also be composed of iron; cannon balls, old armaments, and parts of old structures and vehicles can also be composed of iron.

Ferrous

Metals which are made of or contain iron.

Gnd Trac

Ground Track is the process of finding the exact location of a buried object. Long-buried metals can appear exactly like the surrounding soil and can therefore be very hard to isolate from the soil.

Pull-Tabs

Discarded pull-tabs from beverage containers are the most bothersome trash items for treasure hunters. They come in many different shapes and sizes. Pull-tabs can be eliminated from detection, but some other valuable objects can have a magnetic signature similar to pull-tabs, and will also be eliminated when discriminating out pull-tabs.

Gnd Bal

Ground Balancing is the ability of the detector to ignore, or “see through,” the earth’s naturally occurring minerals, eliminates false signals from severe ground conditions and only sound a tone when a metal object is detected.

Surf Elim

Surface Elimination can improve the accuracy of detection result in soil with mass trash metal. It restrains the signal from trash metal in soil surface layer and balance the signal from large target.

**Preparation**

Parts of the Metal Detector

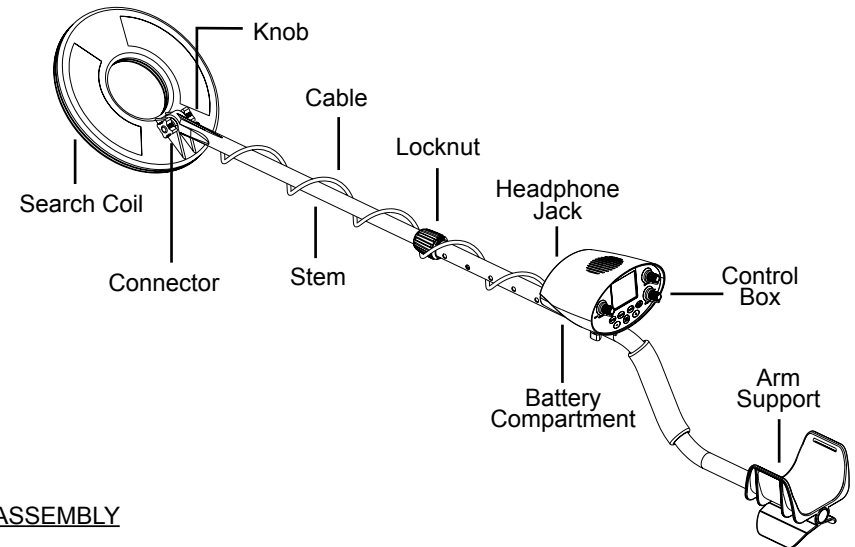

ASSEMBLY

Assembly requires no tools.

1. Open the packing and take out all parts.
2. Join the search coil and the lower stem (fiberglass-made, in black color) then tighten the knob.

- Press the silver button on the upper end of the lower stem and slide the lower stem into the upper stem. Adjust the stem to a length that you feel comfortable when you stand upright with the detector in your hand, and the search coil is level with the ground with your arm relaxed at your side. Then rotate the locking nut counter-clockwise to tighten.
- Wind the search coil cable around the stem. Insert the search coil's plug into the search coil jack on the detector's control housing.
- Assembly of the arm support: Insert the aluminium stem on the arm support into the stem at the end of the main box and tighten the fixing screw properly.

**Caution**

- Do not over-tighten the search coil or use tools such as pliers to tighten it.
- The search coil's plug fits into the connector only in one way. Do not force the plug and also do not pull on the cable or you could damage it.

**BATTERIES**

- This metal detector is powered by two 9-Volt alkaline batteries (not supplied).
- Only use new and proper type of alkaline batteries.
- Do not mix the old and new batteries or different types of batteries.

**Installation**

- Be sure the power switch is at off-position.
- The battery compartment is located under the control box. Slide the battery cover off in the direction of the arrow.
- Take out the two battery connectors from the compartment.
- Join the battery polarities with the connectors.
- Re-install the battery cover.

**Notes**

- Dispose of old batteries promptly and properly, do not bury or burn the batteries.
- If you don't plan to use the unit for a week or more time, remove the batteries. Batteries can leak chemicals that can destroy electronic parts.
- To extend the battery life, exchange the left and right battery after 3-4 hours of operation.
- "LOW BATT" icon will display on bottom right corner of the LCD when the batteries need to be changed.

LCD Screen

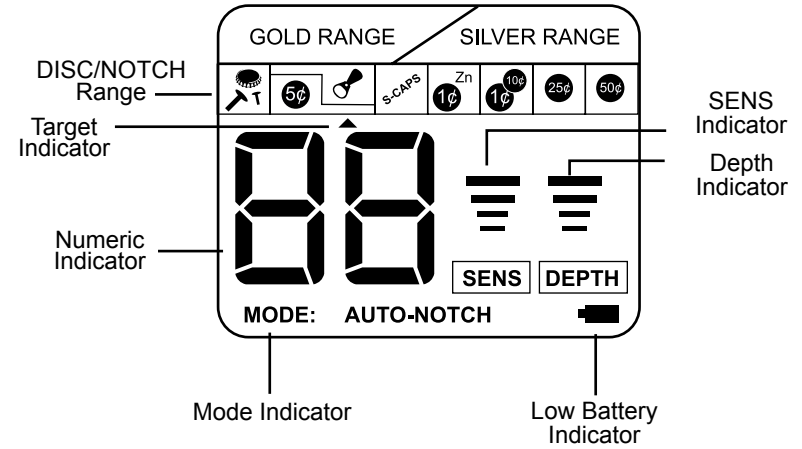

DISC/NOTCH Range Indicator	Indicates current DISC/NOTCH range settings.
Target Indicator	Shows the target category.
Numeric Indicator	Shows the target category with the numeric display. See page 13
Operating Mode Indicator	Shows current operating mode, among the 4 operating modes the detector has DISC, ALL METAL, NOTCH, AUTO-NOTCH.
Low Battery Indicator	Icon will display when the batteries need to be changed.
Depth Indicator	Shows target depth.
Sensitivity Indicator (SENS)	Indicates current sensitivity degree of the machine.

Basic Controls

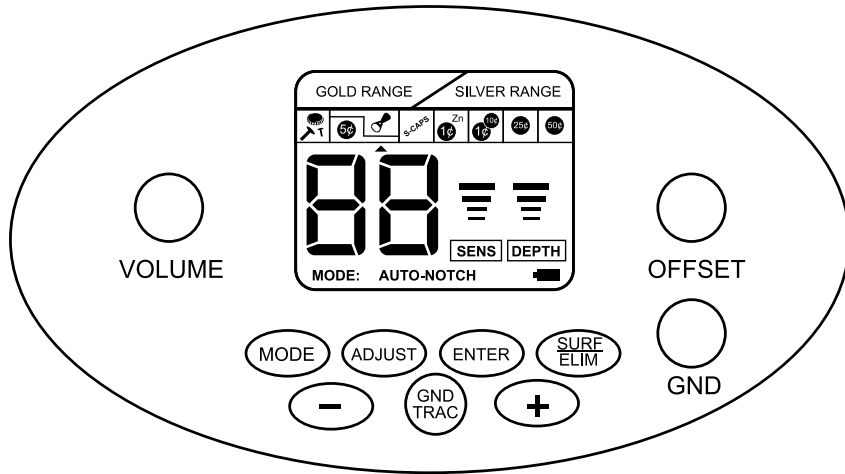

Volume Control / Power	Adjusts the volume level and turns on or off the unit.
Mode	Interchanging the operating mode.
Adjust	+, — ENTER — adjusts the sensitivity, DISC or NOTCH range.
Enter	Used to accept or reject the target in NOTCH mode (it works with + or -)
Surf Elim	Sets the detector to surface elimination mode.
GND TRAC, GND BAL	Sets ground balance in ALL METAL mode and pinpointing a target.
Volume Control / Power	Adjusts the volume level and turns on or off the unit.

**Basic Operation**

Motion and Non-motion Modes

Power On

Turn VOL knob clockwise to turn on the metal detector. The machine runs a self-test first: All display segments will illuminate and the detector sounds high -medium and low tones respectively. Then stays in DISC mode after 2~3 seconds.

ALL METAL Mode

A non-motion mode: In this mode, target is detected with the coil motionless over it, and the detector emits continuous sound (no need to move the coil from side to side). In ALL METAL Mode, adjust GND BAL controller and then press GND

TRAC several times to eliminate ordinary minerals and ores. The detector sounds a medium tone to all targets detected.

DISC.NOTCH and AUTO-NOTCH

Modes are motion modes: There are 3 tones to identify different metals in these modes. Detector can work in auto-ground balance. Sensitivity is adjustable, while GND BAL is not available in these modes. To reject the trash metal, you may adjust DISC or NOTCH range. Motion mode means the coil must be in continuous motion, otherwise target cannot be detected.

Four Operating Modes

Interchangeable among 4 operating modes: DISC, ALL METAL, AUTO-NOTCH, NOTCH.

Press MODE touch pad to change the operating modes in following order: DISC→ALL METAL→AUTO-NOTCH→NOTCH→DISC. The operating mode displays at bottom left corner of the LCD.

DISC mode

Power on the detector, it enters into the default mode DISC automatically. In this mode, the detector can eliminate unwanted objects from the left of the DIS/NOTCH range to the right. DISC/NOTCH indicator shows detector's current discrimination range, and an object's probable identification is indicated by the arrows at the top of the display. SENS shows current sensitivity level. While DEPTH reads out the estimated target depth. Each time a target is detected, DEPTH indicator will illuminate. DEPTH indicator shows the relative depth of the target, the larger the reading is, the farther the target away from the coil.

Adjusting DISC Range

Press ADJ, the display bar of DISC/NOTCH range will blink. Now you can adjust DISC/NOTCH range. Press "+" to increase the range of discrimination, press "-" to decrease it.

ALL METAL Mode

Press MODE to enter into ALL METAL mode, the detector now is in non-motion mode. In this mode, the detector emits only a monotone sound when it finds a target, and DEPTH indicates relative target signal strength. The stronger the signal is, the louder the tone is. GND TRAC is used to locate a coin-sized object precisely. To move the coil above or near the target area, target will be found soon. Please make sure the detector is well ground balanced before using ALL METAL mode. (Please refer to Ground Balancing and PINPOINTING in Non-motion mode.) Target identification is useless in ALL METAL mode. To see target identification and depth, please change the detector into relative motion mode.

NOTCH Mode

To selectively eliminate one or several metals from the categories, you can use NOTCH mode. DISC/NOTCH indicator shows current target discrimination range,

and the probable target identification is indicated by the arrows at the top of the display. SENS shows current sensitivity level. While DEPTH indicates the probable target depth.

#### Adjusting Target NOTCH Range

In NOTCH mode, press ADJ to enter into DISC/NOTCH range setting status. LCD display bar blinks. Press + or - touch pad, one of the arrows in target indicator will flash, press ENT to accept or reject the corresponding metal target. Press again + or -, its right or left arrow will flash, then press ENT to accept or reject another metal target which the current arrow pointing to. Same as the others.

#### AUTO-NOTCH Mode

When the detector is working in AUTO-NOTCH mode: LCD shows "AUTO-NOTCH" at the bottom, it eliminates trash metals automatically and keep the detection for coins. Eliminated trash metals include: Bottle caps, S-CAPS, IRON/FOIL, Pull Tab. DISC/NOTCH range not "adjustable" displays current target identification range. And an object's probable identification is indicated by the arrows at the top of the display. SENS shows current sensitivity level. While DEPTH indicates the probable target's depth.

#### Sensitivity Adjustment

Adjusting Sensitivity in DISC,NOTCH and AUTO-NOTCH MODE Press ADJ to enter into sensitivity setting status. The display bar of "SENS" flashes. Press + to increase the sensitivity level. Press - to decrease it.

Note: Sensitivity is not adjustable in ALL METAL mode.

#### Electromagnetic Interference

The principle use for the Sensitivity Control is to eliminate electromagnetic interference. This metal detector is an extremely sensitive device. The search coil creates its own magnetic field and acts like an antenna. If your detector beeps erratically, probably it detects another electromagnetic field. Common sources of the electromagnetic interference are electric power lines, both suspended and buried, motors, and household appliances like computers and microwave ovens. Some indoor electronic devices, such as dimmer switches used on household lighting, produce severe EMI and can cause the detector to beep erratically. Other metal detectors also produce their own electromagnetic fields. So if you are detecting with a friend, keep two metal detectors at least 20 feet / 6 meters apart.

#### Severe Ground Conditions

Another use for the Sensitivity Control is to reduce false detection signals caused by severe ground conditions. Although this metal detector has specially designed circuit to reduce the ground mineralization, the ground conditions in field cannot be anticipated. Highly magnetic soils found in mountainous area can cause the detector to emit tones when metal objects are not present. High saline content soils and sands can sometimes cause false signal. If the detector emits false, non-repeatable, signals, REDUCE THE SENSITIVITY.

#### Multiple Targets

If you suspect the presence of a deeper target beneath a shallower target, reduce the sensitivity to eliminate the detection of the deeper target, in order to properly locate and identify the shallower target.

#### OFFSET or Frequency Tuning

The detector will be possibly out of order when there is other detector working near it. This is because these detectors have same working frequency which will affect the normal operation. In this case, you can use OFFSET to tune the frequency to lower the interference.

#### Surface Elimination

Press SURF ELIM to enter into or quit Surface Elimination mode.

SURF ELIM only works in DISC/NOTCH mode. It can improve the accuracy of detection result in soil with mass trash metal. It restrains the signal from trash metal in soil surface layer, and balances the signal from large target. But detector's sensitivity is decreased in this mode.

#### Headphone Jack

Using headphones (not supplied) makes it easier to identify subtle changes in the threshold levels for better detection results. Also reduces battery consumption. The metal detector has a stereo headphone jack located on the body of the control panel. We recommend you using headphones in noisy environment.

#### Caution:

- To protect your hearing, set the volume to the lowest setting before you begin listening.
- Extended high volume listening can lead to permanent hearing loss.

#### ATI or Audio Target Identification

Though the LCD can display the buried object, user in the field does not always keep the display screen in his vision. Therefore, we have incorporated an audio feedback to alert the user the nature of buried objects. This audio feedback system first alerts the user the presence and classification of objects, whose nature and location can be confirmed by the LCD display.

The 3-tone audio target identification system functions only in the motion modes of DISC, NOTCH or AUTO-NOTCH. In ALL METAL mode, the detector will emit only a monotone sound. The detector can sound three different tones, depending on the object detected.

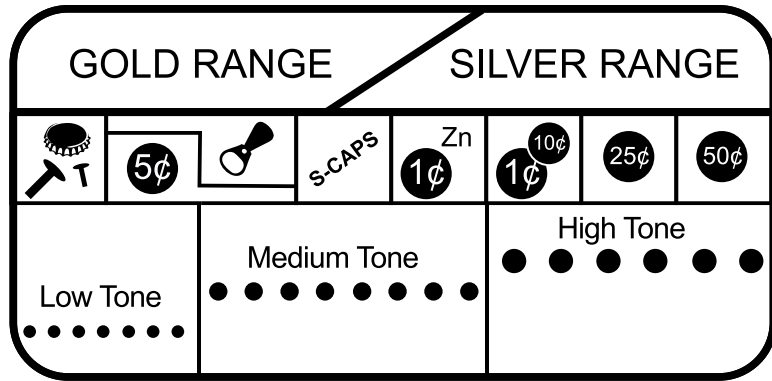

Low Tone	Bottle caps, nickel coins (5¢) small gold objects will induce a low tone.
Medium Tone	Pull-Tabs, S-CAPS, zinc coins, Newer pennies (post-1982), gold objects will induce medium tone.
High Tone	1¢(1950), 10¢, 25¢ and 50¢ will cause high tone.

**Using the Detector**

Reading the Display

Target Indicator

The LCD shows the probable type of the target, as well as the probable depth of the target. The detector will register a repeating, unchanging target identification when a buried target has been located and identified. If the search coil repeatedly passes over the same spot, the target identification reads inconsistently, the target is probably a trash item, or oxidized metal. With practice, you will learn to unearth only the place with repeatable signals come out. Also, the greater the distance between the target and the coil, the less accurate the target identification. Except arrow display, you can also identify the metal type with the numeric display.

GOLD

Gold objects will register at the left side of the LCD scale and will register depending on its size. The smaller the gold object, the further to the left it will register.

Gold	Gold Foil	Will register at the far-left side (same as Iron), Large gold items will register in S-cap or Zinc area. For numeric display, gold will register in 0-50 area.
	Iron	Ferrous objects will register on the far-left side of the target scale. Objects in this category could be worthless scrap, or more valuable iron relics. It will also register in 0-10 area.
	5¢	Nickel and new pull tabs will register here. They will also be in 10-20 numeric area.
	Pull-Tabs	Pull-tabs of older beverage cans will register here. Few new pull-tabs will also register here. Many gold rings will also register here. For numeric display, they will be in 18-25 area.
	S-Caps	Bottle caps with whorl and some small gold will register here. They will also be in 25-40 area
	1¢ - 1¢ (post-1982)	Pennies copper coin registers here. The numeric area is 40-50.
Silver	10¢/1¢	1¢ (pre-1982), 10¢ or aluminium coin will register here. The numeric area is 50-68.
	25¢	Indicates the target may be 25¢, some small silver coins, or large aluminium coins. The numeric area is 68-90.
	50¢	Target may be 50¢, or some large silver coins. The numeric area is 90-99.

Note: The target indications are visual references. Many other types of metal can fall in any of these categories. The detector can indicate the presence of most common metal objects. It is impossible to classify all buried objects accurately.

Depth Indicator

The Depth Indicator is accurate for coin-sized objects. It indicates the relative depth of the target. Large and irregularly-shaped objects will yield less reliable depth readings. When passing over an object, the depth indicator will light up and stay illuminated until another object is scanned. Repeated indication at the same depth level indicates an accurate target detector. If the depth indication varies with each sweep, try sweeping at different angles; there may be more than one target present. With practice, you will learn the difference between accurate readings, multiple targets, and highly erratic readings which evidence trash or irregularly shaped objects.

NOTE: Depth value indication of same target in air is different from that of under the ground.

Indoor Testing

Supplies Needed

- A Nail
- A Quarter
- A 1¢ (post-1982)



1. Remove any metal items that you may be wearing.
2. Turn on the detector.
3. Place the detector on a wooden or plastic table and adjust the search coil so the flat part points upwards toward the ceiling.
5. When in DISC, NOTCH or AUTO-NOTCH mode, evenly sweep the nail 10-12cm above the flat face of the search coil. The detector will emit a low tone when detects the sample, and the arrow pointing to nail in target indicator illuminates. The DEPTH indicator also displays corresponding value. Repeat the above test with a 1¢ (post-1982). Detector sounds medium tone this time, and target indicator arrow points to 1¢. While In the test of 25¢, detector emits high tone and arrow points to 25¢.

NOTE: When the sample is a coin, lay the flat side of the coin parallel with the flat face of the search coil and sweep it evenly, so that the detector can find the target more easily. Sweeping with the side of the coin parallel with the search coil will cause test error and target arrow might be flash and jump.

5. In ALL METAL Mode, move a test sample over the flat side of search coil at a higher location (above than 1 foot) slowly close to the search coil. The detector emits a tone when detects the target, and DEPTH indicator shows relative value. All samples sound one tone in this mode.

Outdoor Testing

Pinpointing (non-motion mode)

Accurate pinpointing takes practice and is best accomplished by crossing sweep the target area.

1. Once a buried target is indicated by a clear tone response, continue sweeping the coil over the target in a narrowing side-to-side motion.

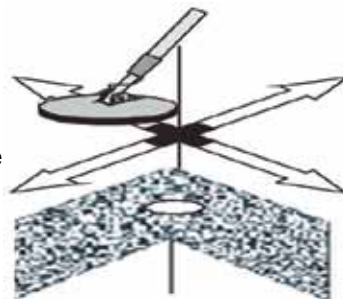

2. Take visual note of the place on the ground where the “beep” sounds.
3. Stop the coil directly over this spot on the ground.
4. Now move the coil straight forward and straight back towards you a couple of times.
5. Again make visual note of the spot on the ground at which the “beep” sounds.
6. If needed, cross sweep the target in “X” pattern at different angles to “zero in” on the exact spot on the ground at which the “beep” sounds.

Coil Movement

When swinging the coil, be careful to keep it level with the ground about 1-1.5 cm from the surface. Never swing the coil like a pendulum. Raising the search coil while sweeping or at the end of a sweep will cause false reading.

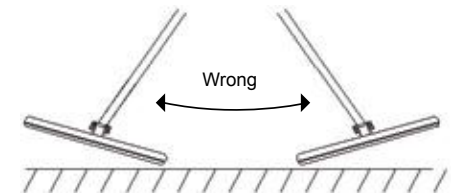

When searching, it's better you sweep the search coil from side to side in an arc line of 7-8 cm motion.

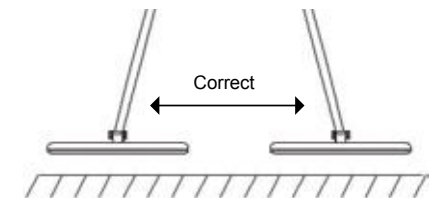

Swing the search coil slowly, overlapping each sweep as you move forward. It is important to sweep the coil at a consistent speed over the ground as you search. After identifying a target, your sweep technique can help in identifying both the location and the nature of the target. If you encounter a weak signal, try moving the coil in short, rapid sweeps over the target zone. Such a short rapid sweep may provide a more consistent target identification.

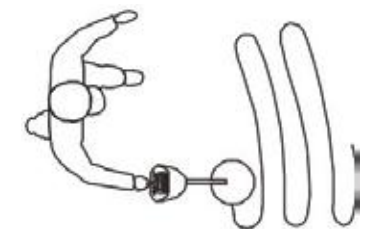

Most valuable objects will respond with a repeatable tone. If the signal does not repeat after sweeping the coil directly over the suspected target a few times, it is more than likely trash metal.

Crossing the target zone with multiple intersecting sweeps at multiple angles is another way to verify the repeatability of the signal, and the potential of the buried target. To use this method, walk around the target area in a circle, sweeping the coil across the target repeatedly, every 30 to 40 degrees of the circle, about ten different angles as you walk completely around the target. If a high-tone target completely



disappears from detection at a given angle, chances are that you are detecting oxidized ferrous metals, rather than a silver or copper object. If the tone changes at different angles, you may have encountered multiple objects. If you are new to the hobby, you may want to dig all targets at first. With practice in the field, you will learn to better discern the nature of buried objects by the nature of the detector's response.

You may encounter some false signals as you proceed. False signals occur when the detector beeps without target being present. False signals can be induced by electromagnetic interference, oxidation, or highly mineralized ground soils. If the detector beeps once, but does not repeat the signal with several additional sweeps over the same spot, there is probably no target present.

When searching very trashing ground, it is best to scan small areas with slow, short sweeps. You will be surprised just how much trash metal and foil you will find in some areas. The trashiest areas have been frequented by the most people, and frequently hold the most promise for finding the most lost valuables.

### Ground Balancing

Before using the ALL METAL mode, it is necessary to "Ground Balance" your detector, this ground balancing adjustment offsets the effects of minerals and salts in the ground.

To GROUND BALANCE your detector:

1. Use the ALL METAL mode to find a patch of ground which is free of metal objects. You will use this section of ground to test the detector. The presence of any metal objects in this area will interfere with this procedure.
2. Lift the search coil waist high in the air.
3. Begin with the ground balance (GND BAL) KNOB in the P position. Rotate slightly the GND BAL knob from P counter clockwise.
4. Press GND TRAC.
5. Lower the search coil to the ground, maintaining it elevated about 1-1.5 cm above the surface (be sure that this ground does not contain metal).

If the detector emits sound with the search coil 1-1.5 cm over the ground, repeat the above steps 3 and 4.

If the detector remains silent with the search coil 1-1.5 cm over the ground, no further adjustment is necessary; the detector is "GROUND BALANCED". Otherwise, you have to adjust the sensitivity.

It is important to rotate the GND BAL knob in small increments in order to find the first setting (clockwise) at which the detector remains silent. To insure yourself of the optimal adjustment, rotate the knob slightly clockwise from a silent-adjusted position to check for the most clockwise silent position possible. If the KNOB is over-adjusted in the clockwise direction, the detector can lose sensitivity.

As you search in different areas, it is necessary to verify the ground balance setting periodically following the above procedure. Even in a geographical area, ground conditions can be different. Varying elevations, proximity to water, and concentrations of rock, sand or clay can all affect ground condition and sometimes require recalibration with the ground balance knob.

### Pinpointing (non-motion mode)

Coil sweep technique is not important in this mode. Rather, user's retuning is critical. The detector does not automatically adjust to as ground and environmental conditions changing. The operator is required to make the adjustment by himself.

### Retuning

Keep the coil still, just above the ground surface. Make sure that the spot on the ground you chose for tuning does not contain metal; pass over the area with the coil again to insure that the detector does not emit a tone and LCD does not display any signal.

### Detection Field

The detection field depends on the size of the target.

### Large Objects

After a target is detected, LCD displays sensitivity level and a medium tone beeps. If you lift the coil to a distance around 2cm above the ground, the signal displayed on the LCD is almost same and the tone does not fade, you may have detected a large or irregularly shaped object. Further lift the coil off, increments on LCD decreases obviously and the tone level reduces rapidly. Outline the object with slow coil movements at the same height.

### Small Objects

After detecting a target, LCD displays a low sensitivity level and the speaker emits a faint sound. While maintaining the coil at this height above the ground, move the coil from side-to-side. Note the spot where the tone is loudest, and the sensitivity level is largest (usually increments on LCD changes more sensitive than the sound changes). Then move the coil toward the ground to zero-in on the target's location. A coin-size object will be detected when the object enters the range of the inner coil.

### Trouble Shooting

#### Detector emits false signal in field use.

Sensitivity is set too high, please lower the sensitivity till the false signal disappears. Move the search coil slowly. Oxidized metal may cause the false signal. If the signal is not repeatable when search coil swept over a target, the target usually is a trash.

#### LCD displays multiple target categories or emits several sounds at one time.

There might be over one kind of metal, or the detector cannot identify the target. Sometimes, oxidized metal also cause the excursion of target arrow and tone. Too high sensitivity is another probable reason.

#### Detector works unstable or read by mistake.

There might be another metal detector working or electric line nearby.

### Care and Maintenance

Handle the detector gently and carefully. Dropping it can damage circuit boards and cases and can cause the detector to work improperly.

Use the detector only in normal temperature environments. Temperature extremes can shorten the life of electronic devices, damage the cases of the detector.

Keep the detector away from dust and dirt, which can cause premature wear of parts.

Wipe the detector with a damp cloth occasionally to keep it looking new. Do not use harsh chemicals, cleaning solvents, or strong detergents to clean the detector.

#### CAUTION:

- The search coil is water proof, and it can be completely under the fresh water or sea water. Please be careful to avoid the water enter into machine body. Sea water may erode the search coil. Please always use fresh water to clean the search coil after detection in sea water.
- Change or damage the inner components will cause the detector fault, and such fault is not within our warranty.

## 1 YEAR LIMITED WARRANTY

### Metal Detector

WINBEST® by BARSKA®, as manufacturer, warrants this new product to be free of original defects in materials and/or workmanship for the length of time specified by this warranty. This warranty does not include damage caused by abuse, improper handling, installation, maintenance, normal wear-and-tear, unauthorized repairs or modifications and tampering in anyway.

This warranty is limited to the original purchaser and is not transferable. This warranty applies only to products purchased in the United States of America and Canada.

In the event of a defect within 30 days, the consumer must return the defective unit to the WINBEST® by BARSKA® dealer (the place of purchase) at his/her own expense.

Beyond 30 days, WINBEST® by BARSKA® products should be sent to the following address for warranty repairs. Products must be packed carefully and sturdily to prevent damage in transit, and returned freight prepaid to:

WINBEST® by BARSKA®  
855 Towne Center Drive  
Pomona, CA 91767

For additional and updated information  
please visit [www.barska.com](http://www.barska.com)

Please email [info@barska.com](mailto:info@barska.com) or call 1.888.666.6769 for Return Merchandise Number (RMA#) before any returns.

NOTE: All merchandise received without a valid RMA# will be returned to shipper at his/her own expense.

Please include all of the following when returning WINBEST® by BARSKA® products for service and/or replacement:

1. Please write your complete details (Name, Address, Telephone #, E-mail address, RMA#, etc.)
  2. Purchase receipt or Proof of Purchase. (Original/Copy)
  3. A brief explanation of the defect
  4. A Check/Money Order of \$35.00 to cover inspection, shipping and handling
- \*Please allow 6-8 weeks for delivery

This product will either be replaced or repaired at the discretion of the warrantor. If it's a discontinued item, we will replace the product with an equivalent product. Should the repair not be covered by this warranty, an estimate will be sent for your approval. Non-warranty repairs or refurbishing are always provided at a reasonable cost.

WINBEST® by BARSKA® shall not be liable for any consequential, incidental and/or contingent damages whatsoever. We will not pay shipping, insurance or transportation charges from you to us, or any import fees, duties and or taxes. This warranty supersedes all previous Winbest® by BARSKA warranties.