



# User's Manual for Biometric Safe

Read all instructions before using this safe.

## WARNING

- New Safe is in Factory Default mode, ANY fingerprint can open the safe. Only successful registered fingerprint can terminate Factory Default mode.
- Register at least two different fingerprints and test a few times before closing the safe door.
- Test with a non-registered fingerprint. If the safe opens, the safe remains in Factory Default mode.
- Avoid leaving safe door open and unattended; it will allow unauthorized individuals to add their fingerprints and/or reprogram the safe, gaining full access to the safe and the contents.
- Test the Emergency Keys and store them in a secure place, NOT inside of the safe.
- To maximize the security and performance of the safe, test registered fingerprints every 6 months.

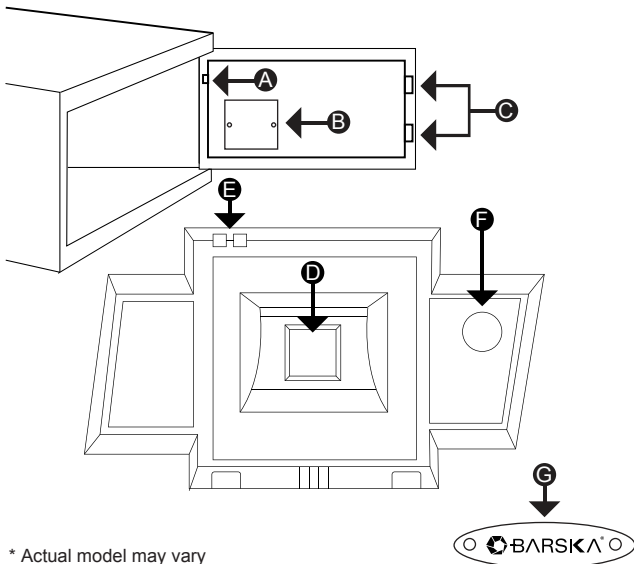

\* Actual model may vary

- A. Initialization Button
- B. Battery Compartment
- C. Bolts
- D. Fingerprint Scanner
- E. Indicator Lights
- F. Wake-Up Button
- G. Logo Plate and Emergency Key Access

## 1. INSTALL BATTERIES

1. Remove Battery Compartment (B) cover
2. Insert 4 AA batteries and restore battery cover
3. Bolts (C) automatically extend when batteries are inserted  
To retract bolts:
  - Press and release Wake-Up Button (F)
  - Place any finger on the Fingerprint Scanner (D)
  - Bolts will retract

## 2. FINGERPRINT REGISTRATION

IMPORTANT:

The safe is in Factory Default mode, ANY fingerprint can open the safe. Only successful registered fingerprint can terminate Factory Default mode

During registration the door must remain open and the Bolts (C) must be in the retracted position. Otherwise, the fingerprint will not be saved

To retract bolts:

- Press and release Wake-Up Button (F)
- Place any finger on Fingerprint Scanner (D)
- Bolts will retract

1. Press and release Initialization Button (A)
2. Immediately place a finger on the Fingerprint Scanner (D)
  - Hold finger still
  - 1 beep will be heard recognizing the fingerprint; followed by 2 consecutive beeps
  - Remove finger
  - Registration is complete

### Successful Registration

Registration is successful when a total of 3 beeps are heard

### Unsuccessful Registration

2 beeps will be heard and red light will flash; repeat registration process again

3. To register another fingerprint – repeat steps 1 - 2

## 3. TEST A REGISTERED FINGERPRINT

1. With safe door open, press and release Wake-Up Button (F)
  - Bolts (C) will extend
2. Press and release Wake-Up Button (F)
  - Place a non-registered finger on the Fingerprint Scanner (D)
  - Bolts will stay extended
3. If the bolts retract with a non-registered fingerprint, registration was unsuccessful; and safe remains in Factory Default mode
  - Repeat steps under FINGERPRINT REGISTRATION

4. Press and release Wake-Up Button (F)
  - Place a registered finger on the Fingerprint Scanner (D)
  - Bolts will retract

## 4. CLOSE/OPEN SAFE DOOR

CLOSE: Close door, press and release Wake-Up Button (F)  
- Bolts will extend

OPEN: Press and release Wake-Up Button (F)  
- Place a registered finger on Fingerprint Scanner (D)  
- Bolts will retract

## 5. SOUND OPTION

To turn Sound on/off: Press and Hold the Initialization Button (A) for about 6 seconds until there is a beep and a green flash. RELEASE the Initialization Button

## 6. DOOR OPEN ALARM

Regardless of the beep sound option chosen (either On or Off) the door alarm is fixed to beep

The alarm is activated when the safe door is open and Bolts (C) are retracted

More than 2 minutes, the safe will start beeping every 10-20 seconds

After 5 minutes, safe will go into sleep mode and no beep will be heard.

Close safe door, press and release Wake-Up Button (F) to extend the Bolts (C) to cease the alarm

With the safe door open and the Bolts (C) extended, no lights or beeping will be heard

## 7. OPEN SAFE WITH EMERGENCY KEY

1. To expose the Emergency Key access, remove Logo Plate (G) screws with provided Allen wrench
2. Insert Emergency Key into key access, and turn clockwise to open

NOTE: Store Emergency Keys in a secure place, NOT inside of the safe

## 8. DELETE ALL STORED FINGERPRINTS / RESET TO FACTORY DEFAULT MODE

1. Open safe, remove Battery Compartment (B) cover and all 4 AA batteries
2. Press and release Wake-Up Button (F) a few times until no beeps are heard
3. Press and HOLD the Initialization Button (A)
  - Re-insert batteries, on the 4th battery you will hear 1 beep, followed by 3 consecutive beeps indicating safe is in Factory Default mode
4. RELEASE Initialization Button (A)
5. Repeat steps 1-3 if a total of 3 beeps are not heard
6. Restore Battery Compartment (B) cover
7. All fingerprints stored in the safe have been deleted

NOTE: The safe is in Factory Default mode, ANY fingerprint can open the safe

## 9. LOW BATTERY WARNING

1. When the door is closed and an alarm that has never been heard during normal operation is heard, batteries are low
2. Replace batteries immediately
  - Open safe, remove Battery Compartment (B) cover and all 4 AA batteries
  - Insert 4 new AA batteries and restore Battery Compartment (B) cover

NOTE: All registered fingerprints remain stored

## 10. CARE AND MAINTENANCE

- To maximize the security and performance of the safe, keep Fingerprint Scanner (D) clean; use a dry cloth to remove any smudges or prints off the Fingerprint Scanner after each use
- Test registered fingerprints every 6 months
- Keep liquids away from the control panel. Spills on the control panel will cause damage and possibly electric shock
- Secure safe in a proper area to prevent from falling and causing damage or injury
- DO NOT disassemble the product. For all repairs, contact BARSKA Customer Service
- DO NOT use chemicals or cleaning agents to clean the safe

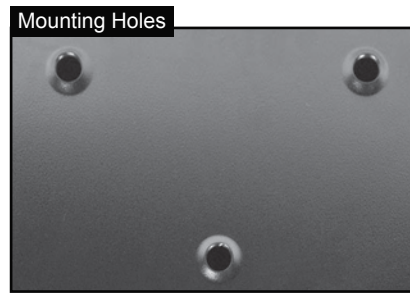

\* Actual model may vary

## 11. MOUNTING INSTRUCTIONS

The safe may be mounted to a wall or floor. Be aware of the load bearing. Failure to do so can result in personal injury and/or damage to property. Use appropriate tools when performing work and always use eye protection

### Wall Mounting

Do not mount the safe without anchoring to the wall

- Find the studs in the wall, at your desired location. Most studs are 16 inches or 24 inches apart
- Check the wall for concealed wires or pipes
- Measure the location of the pre-set drill holes; mark their exact position onto the wall ensuring that the studs or anything else behind will not interfere
- Drill the appropriate size holes for the anchors you are using
- Carefully press the anchor into the holes at this time
- Mount the safe by running screws from inside of the safe and securing to anchors; ensure the safe is mounted securely

### Floor Mounting

- Use proper drill tools depending on the type of floor you are mounting the safe (wood, tile, or concrete)
- Measure the location of the pre-set drill holes; mark their exact position onto the floor
- Drill the appropriate size holes for the anchors you are using
- Carefully press the anchor into the holes at this time
- Mount the safe by running screws from inside of the safe and securing to anchors; ensure the safe is mounted securely



## 1 YEAR LIMITED WARRANTY

### Biometric Safe

BARSKA warrants this new safe to be free of original defects in material and/or workmanship under normal use for a period of twelve (12) months from the date product is received by purchaser. This warranty does not include damage caused by improper installation or maintenance. Damage from misuse, abuse, accident (such as dropping), normal wear and tear, fire, flood, or acts of nature. Damage from service or repairs other than those performed by BARSKA. Labor, cost and shipping charges for the removal and replacement of defective parts beyond the initial twelve-month warranty period. All transportation and shipping charges. Removing or altering the seal under any circumstances will automatically void the warranty.

This warranty is limited to original purchaser and is not transferable. This warranty applies only to products purchased in the United States.

Please email [info@barska.com](mailto:info@barska.com) or call 1.888.666.6769 for Return Merchandise Number (RMA#) before any returns. The RMA number must appear on the outside of the shipping package. Product must be packed carefully and sturdily in its original packaging to prevent damage in transit and returned freight pre-paid to:

BARSKA OPTICS  
Repair Department  
855 Towne Center Drive  
Pomona, CA 91767

Please include all of the following when returning BARSKA products for service and/or replacement:

1. Please write your complete details (Name, Address, Telephone #, E-mail address, RMA#, etc.)
2. Purchase receipt or Proof of Purchase. (Original/Copy)
3. A brief explanation of the defect.
4. A Check/Money Order of \$40.00 to cover inspection, shipping and handling.

\*Please allow 6-8 weeks for delivery.

BARSKA will examine and test returned product and repair or replace defective part(s) or units with new part(s) or a new unit if necessary within the warranty period. Purchaser is required to remit \$40.00 to BARSKA for return shipping and handling at time product is returned. If repair is required after warranty period expiration, purchaser will be charged for replacement parts and return shipping.

BARSKA® Optics shall not be liable for any consequential, incidental and/or contingent damages whatsoever. We will not pay shipping, insurance or transportation charges from you to us, or any import fees, duties and or taxes. This warranty supersedes all previous BARSKA® Optics warranties.

BC323

4/13